

WIDIA-GTD™ Quick Ship Service

Rely on the WIDIA™ Quick Ship Service program to deliver the special taps you need, when and where you need them. Within minutes, we can quote, process, and release your order to the factory.

Quick Ship Service



Features and Benefits

- Non-standard tap sizes, pitches, PDs, coatings, etc.
- The use of standard blank gives a quick turnaround.
- Variations in design to suit your needs.
- Fast service, high quality.

How to Order Quick Ship

Quick Ship

WIDIA-GTD™ is now offering a Quick Ship Service, which supports its standard tap portfolio by being able to produce a basic custom tap from a blank with competitive lead times, with quality that is absent from the traditional Quick Ship companies. We will take a standard blank and modify to suit the customer needs based on the product boundaries described below.

WIDIA™ leads the industry in quoting technology. Experienced quotation specialists and product engineers use in-house designed software to generate a quote from a customer inquiry and design cutting tools with the requested features, modifications, options, and surface treatments.

Use the following outline when selecting a tap:

1. Determine the tap that meets your cutting tool needs. For assistance, consult the Tap Selection Guide on pages V2–V17 Of the WIDIA Master Catalog (A-15-04580).
2. If the style, size, and/or quantity is not listed, consult customer service for a factory quote. WIDIA is fully equipped and ready to design your tool to your unique specifications.

Please use the following guidelines when placing an order:

- | | |
|-------------------------------------|---|
| 1. Tap size. | 7. Chamfer (taper, plug, modified bottom, or bottom). |
| 2. Catalog blank number. | 8. Surface treatments. |
| 3. Pitch diameter and class of fit. | 9. Additional features or options. |
| 4. Depth of tapped hole. | |
| 5. Depth of thread required. | |
| 6. Component material. | |

NOTE: If you do not specify the pitch, number of flutes, and/or chamfer, standard specifications will be applied and shipped uncoated.

Any additional information, such as material to be tapped, type of hole, and any general dimensions, such as overall length and shank diameter, will ensure a correct tap for your application.

Features and Boundaries (Built out in a form)

■ Surface Treatments

Features	Limits Inch and Metric
Thread Forms	UNC, UNF, M, MF, STI, UNJ, UNJEF, UNS, UN
Thread size	Hand Tap #0 to 1" M1.5 to M25 Spiral Point #0 to 1" M1.5 to M25 Spiral Flute #2 to 1" M2 to M24 Form Taps #0 to 3/4" M1.6 to M12
Thread TPI/Pitch	TPI 100 to 4 Pitch 0.3-3.0
Tolerance	Max H Limit 12 Max D limit 12 (depending on thread diameter)
Chamfer Type	Taper, Plug, Bottom
Surface Treatments	Uncoated, Tin, Steam Oxide, Nitride, Steam Oxide/Nitride, TiCN, TiAlN, CrN, TiN CrC/C

NOTE: Add to lead-time designated for special taps.

■ Additional Features

Feature/options
Controlled root (minor diameter +/- .001") double lead interrupted threads, taper or straight, odd number
External centers removed, special marking

■ Coating Recommendation Chart

Material Group	uncoated	oxide	nitride	TiN	TiCN	TiAlN	CrN	TiN CrC/C
P	○	○		○	●	○		●
M	○	○		○		○	○	●
K	○	○	○	○	●	○		○
N	○		○	○				○
S	○		○	○		●	○	●
H								
speed (SFM) increase	0%	0%	0%	50%	50%	100%	100%	100%

● first choice
○ alternate choice

■ Delivery times

(from the date the order was placed)

Delivery times
Uncoated 5–7 days
Coated 7–12 days

■ Pricing based on Order Qty Price break table

	Min	Max
	5	24
	25	49
	50	72

Specials from Blanks • General Applications • HSS

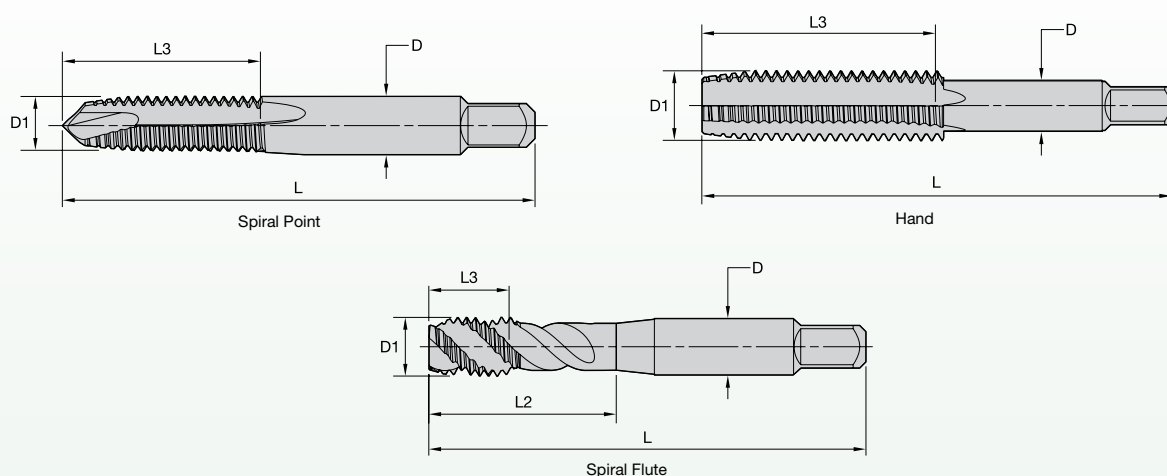

style	uncoated 2-flute	uncoated 3-flute	uncoated 4-flute	uncoated 6-flute	L	L3	L2	D	max H limit	max TPI
#0										
Hand – T, P, B	64250	-	-	-	1.63	0.31	-	0.141	3	100
Spiral-Point Gun – P, B	64350	-	-	-	1.63	0.31	-	0.141	3	100
#1										
Hand – T, P, B	64251	-	-	-	1.69	0.38	-	0.141	4	100
Spiral-Point Gun – P, B	64351	-	-	-	1.69	0.38	-	0.141	4	100
#2										
Hand – T, P, B	64252	64264	-	-	1.75	0.44	-	0.141	4	100
Spiral-Point Gun – P, B	64352	-	-	-	1.75	0.44	-	0.141	4	100
Regular Spiral – P, B	65160	-	-	-	1.75	0.44	-	0.141	4	100
Fast Spiral – P, B	65161	-	-	-	1.75	0.44	-	0.141	4	100
#3										
Hand – T, P, B	64253	64265	-	-	1.81	0.50	-	0.141	5	100
Spiral-Point Gun – P, B	64353	-	-	-	1.81	0.50	-	0.141	5	100
Regular Spiral – P, B	64455	-	-	-	1.81	0.50	-	0.141	5	100
Fast Spiral – P, B	64466	-	-	-	1.81	0.50	-	0.141	5	100
#4										
Hand – T, P, B	64254	64266	-	-	1.88	0.56	-	0.141	5	100
Spiral-Point Gun – P, B	64354	-	-	-	1.88	0.56	-	0.141	5	100
Regular Spiral – P, B	64456	-	-	-	1.88	0.56	-	0.141	5	100
Fast Spiral – P, B	64467	-	-	-	1.88	0.56	-	0.141	5	100
Oversized										
Hand – T, P, B	65730	-	-	-	1.88	0.56	-	0.141	11	100
Spiral-Point Gun – P, B	64735	-	-	-	1.88	0.56	-	0.141	11	100
#5										
Hand – T, P, B	64255	64267	-	-	1.94	0.63	-	0.141	5	100
Spiral-Point Gun – P, B	64355	-	-	-	1.94	0.63	-	0.141	5	100
Regular Spiral – P, B	64457	-	-	-	1.94	0.63	-	0.141	5	100
Fast Spiral – P, B	64468	-	-	-	1.94	0.63	-	0.141	5	100
Oversized										
Hand – T, P, B	65731	-	-	-	1.94	0.63	-	0.141	11	100
Spiral-Point Gun – P, B	64736	-	-	-	1.94	0.63	-	0.141	11	100

(continued)

(continued)

Specials from Blanks • General Applications • HSS

style	uncoated 2-flute	uncoated 3-flute	uncoated 4-flute	uncoated 6-flute	L	L3	L2	D	max H limit	max TPI
#6										
Hand — T, P, B	64256	64268	64836	-	2.00	0.69	-	0.141	7	100
Spiral-Point Gun — P, B	64356	64839	-	-	2.00	0.69	-	0.141	7	100
Regular Spiral — P, B	-	65167	-	-	2.00	0.38	0.69	0.141	7	100
Fast Spiral — P, B	-	65172	-	-	2.00	0.38	0.69	0.141	7	100
Oversized										
Hand — T, P, B	65732	65735	-	-	2.00	0.69	-	0.141	13	100
Spiral-Point Gun — P, B	64737	65182	-	-	2.00	0.69	-	0.141	13	100
#8										
Hand — T, P, B	64257	64269	64278	-	2.13	0.75	-	0.168	7	100
Spiral-Point Gun — P, B	64357	65193	-	-	2.13	0.75	-	0.168	7	100
Regular Spiral — P, B	-	65168	-	-	2.13	0.38	0.75	0.168	7	100
Fast Spiral — P, B	-	64476	-	-	2.13	0.38	0.75	0.168	7	100
Oversized										
Hand — T, P, B	65733	65736	64811	-	2.13	0.75	-	0.168	13	100
Spiral-Point Gun — P, B	64738	65183	-	-	2.13	0.75	-	0.168	-	100
#10										
Hand — T, P, B	64258	64270	64279	-	2.38	0.88	-	0.194	7	100
Spiral-Point Gun — P, B	64358	65142	64840	-	2.38	0.88	-	0.194	7	100
Regular Spiral — P, B	-	65169	-	-	2.38	0.50	0.88	0.194	7	100
Fast Spiral — P, B	-	64477	-	-	2.38	0.50	0.88	0.194	7	100
Oversized										
Hand — T, P, B	65734	65737	64812	-	2.38	0.88	-	0.194	13	100
Spiral-Point Gun — P, B	64739	65184	-	-	2.38	0.88	-	0.194	13	100
#12										
Hand — T, P, B	64260	65692	64281	-	2.38	0.94	-	0.220	7	100
Spiral-Point Gun — P, B	64360	65143	-	-	2.38	0.94	-	0.220	7	100
Regular Spiral — P, B	-	65171	-	-	2.38	0.50	0.94	0.220	7	100
Fast Spiral — P, B	-	64479	-	-	2.38	0.50	0.94	0.220	7	100
Oversized										
Hand — T, P, B	-	65738	65752	-	2.38	0.94	-	0.220	13	100
Spiral-Point Gun — P, B	64740	-	-	-	2.38	0.94	-	0.220	13	100
1/4"										
Hand — T, P, B	64261	64272	64282	-	2.50	1.00	-	0.255	7	80
Spiral-Point Gun — P, B	64361	64376	64832	-	2.50	1.00	-	0.255	7	80
Regular Spiral — P, B	-	64470	-	-	2.50	0.63	1.00	0.255	7	80
Fast Spiral — P, B	-	64480	-	-	2.50	0.63	1.00	0.255	7	80
Oversized										
Hand — T, P, B	-	65739	64813	-	2.50	1.00	-	0.255	13	80
Spiral-Point Gun — P, B	-	64741	65186	-	2.50	1.00	-	0.255	13	80
5/16"										
Hand — T, P, B	64262	64273	64283	-	2.72	1.13	-	0.318	7	80
Spiral-Point Gun — P, B	64362	64377	-	-	2.72	1.13	-	0.318	7	80
Regular Spiral — P, B	-	64471	-	-	2.72	0.69	1.12	0.318	7	80
Fast Spiral — P, B	-	64481	-	-	2.72	0.69	1.12	0.318	7	80
Oversized										
Hand — T, P, B	-	65740	64814	-	2.72	1.13	-	0.318	13	80
Spiral-Point Gun — P, B	-	64742	65187	-	2.72	1.13	-	0.318	13	80

(continued)

Pricing Based on Order Quantity	
min	max
5	24
25	49
50	72

(continued)

Specials from Blanks • General Applications • HSS

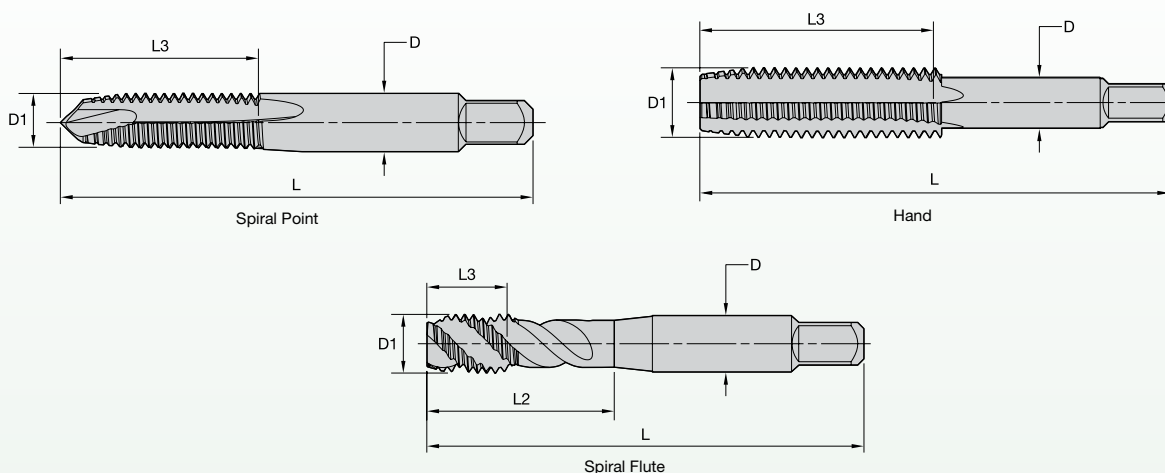

style	uncoated 2-flute	uncoated 3-flute	uncoated 4-flute	uncoated 6-flute	L	L3	L2	D	max H limit	max TPI
3/8"										
Hand — T, P, B	64263	64274	64284	-	2.94	1.25	-	0.381	7	80
Spiral-Point Gun — P, B	64854	64378	-	-	2.94	1.25	-	0.381	7	80
Regular Spiral — P, B	-	64472	-	-	2.94	0.75	1.25	0.381	7	80
Fast Spiral — P, B	-	64482	-	-	2.94	0.75	1.25	0.381	7	80
Oversized										
Hand — T, P, B	-	65741	64815	-	2.94	1.25	-	0.381	13	80
Spiral-Point Gun — P, B	-	64767	-	-	2.94	1.25	-	0.381	13	80
7/16"										
Hand — T, P, B	-	64276	64286	-	3.16	1.44	-	0.323	15	80
Spiral-Point Gun — P, B	-	64380	-	-	3.16	1.44	-	0.323	15	80
Regular Spiral — P, B	-	64474	-	-	3.16	0.88	-	0.323	15	80
Fast Spiral — P, B	-	64484	-	-	3.16	0.88	-	0.323	15	80
1/2"										
Hand — T, P, B	-	64277	64287	65693	3.38	1.66	-	0.367	15	80
Spiral-Point Gun — P, B	-	64381	-	-	3.38	1.66	-	0.367	15	80
Regular Spiral — P, B	-	64475	-	-	3.38	0.94	-	0.367	15	80
Fast Spiral — P, B	-	64485	-	-	3.38	0.94	-	0.367	15	80
9/16"										
Hand — T, P, B	-	65100	64288	65694	3.59	1.66	-	0.429	15	64
Spiral-Point Gun — P, B	-	64382	64826	-	3.59	1.66	-	0.429	15	64
Regular Spiral — P, B	-	-	64496	-	3.59	1.00	-	0.429	15	64
Fast Spiral — P, B	-	-	64502	-	3.59	1.00	-	0.429	15	64
5/8"										
Hand — T, P, B	-	65101	64289	65695	3.81	1.81	-	0.480	15	64
Spiral-Point Gun — P, B	-	64383	64838	-	3.81	1.81	-	0.480	15	64
Regular Spiral — P, B	-	-	64497	-	3.81	1.09	-	0.480	15	64
Fast Spiral — P, B	-	-	64503	-	3.81	1.09	-	0.480	15	64
11/16"										
Hand — T, P, B	-	-	64290	65696	4.03	1.81	-	0.542	15	64
Spiral-Point Gun — P, B	-	64384	-	-	4.03	1.81	-	0.542	15	64
Regular Spiral — P, B	-	-	64498	-	4.03	1.09	-	0.542	15	64
Fast Spiral — P, B	-	-	64504	-	4.03	1.09	-	0.542	15	64

(continued)

(continued)

Specials from Blanks • General Applications • HSS

style	uncoated 2-flute	uncoated 3-flute	uncoated 4-flute	uncoated 6-flute	L	L3	L2	D	max H limit	max TPI
3/4"										
Hand — T, P, B	-	65103	64291	65697	4.25	2.00	-	0.590	15	64
Spiral-Point Gun — P, B	-	64385	64829	-	4.25	2.00	-	0.590	15	64
Regular Spiral — P, B	-	-	64499	-	4.25	1.22	-	0.590	15	64
Fast Spiral — P, B	-	-	64505	-	4.25	1.22	-	0.590	15	64
13/16"										
Hand — T, P, B	-	-	64292	65698	4.47	2.00	-	0.652	15	64
Spiral-Point Gun — P, B	-	64386	-	-	4.47	2.00	-	0.652	15	64
Regular Spiral — P, B	-	-	65690	-	4.47	1.22	-	0.652	15	64
Fast Spiral — P, B	-	-	65691	-	4.47	1.22	-	0.652	15	64
7/8"										
Hand — T, P, B	-	-	64293	65699	4.69	2.22	-	0.697	15	64
Spiral-Point Gun — P, B	-	64387	-	-	4.69	2.22	-	0.697	15	64
Regular Spiral — P, B	-	-	64500	-	4.69	1.34	-	0.697	15	64
Fast Spiral — P, B	-	-	64506	-	4.69	1.34	-	0.697	15	64
15/16"										
Hand — T, P, B	-	-	64294	65700	4.91	2.22	-	0.760	15	64
Spiral-Point Gun — P, B	-	65144	-	-	4.91	2.22	-	0.760	15	64
Regular Spiral — P, B	-	-	65173	-	4.91	1.34	-	0.760	15	64
Fast Spiral — P, B	-	-	65174	-	4.91	1.34	-	0.760	15	64
1"										
Hand — T, P, B	-	-	64295	65701	5.13	2.50	-	0.800	15	64
Spiral-Point Gun — P, B	-	64388	-	-	5.13	2.50	-	0.800	15	64
Regular Spiral — P, B	-	-	64501	-	5.13	1.50	-	0.800	15	64
Fast Spiral — P, B	-	-	64507	-	5.13	1.50	-	0.800	15	64

style	uncoated 2-flute	uncoated 3-flute	uncoated 4-flute	uncoated 6-flute	L	L3	L2	D	max D limit	pitch min
M1.5										
Hand — T, P, B	65288	-	-	-	1.63	0.31	-	0.141	3	0.30
Spiral-Point Gun — P, B	65381	-	-	-	1.63	0.31	-	0.141	3	0.30
M1.6										
Hand — T, P, B	65708	-	-	-	1.69	0.31	-	0.141	3	0.30
Spiral-Point Gun — P, B	65766	-	-	-	1.69	0.31	-	0.141	3	0.30
M1.8										
Hand — T, P, B	65289	-	-	-	1.69	0.38	-	0.141	4	0.30
Spiral-Point Gun — P, B	65382	-	-	-	1.69	0.38	-	0.141	4	0.30
M2										
Hand — T, P, B	65290	65301	-	-	1.75	0.44	-	0.141	4	0.30
Spiral-Point Gun — P, B	65383	-	-	-	1.75	0.44	-	0.141	4	0.30
Regular Spiral — P, B	65479	-	-	-	1.75	0.44	-	0.141	4	0.30
Fast Spiral — P, B	65506	-	-	-	1.75	0.44	-	0.141	4	0.30
M2.2										
Hand — T, P, B	-	65713	-	-	1.75	0.44	-	0.141	4	0.30
Spiral-Point Gun — P, B	65767	-	-	-	1.75	0.44	-	0.141	4	0.30
Fast Spiral — P, B	65773	-	-	-	1.75	0.44	-	0.141	4	0.30

(continued)

Pricing Based on Order Quantity

min	max
5	24
25	49
50	72

(continued)

Specials from Blanks • General Applications • HSS

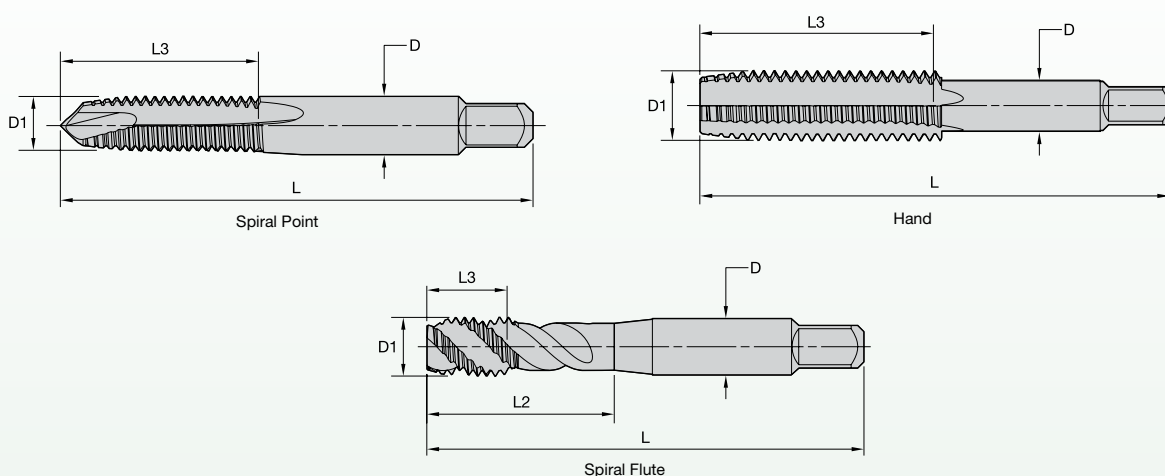

style	uncoated 2-flute	uncoated 3-flute	uncoated 4-flute	uncoated 6-flute	L	L3	L2	D	max D limit	pitch min
M2.5										
Hand — T, P, B	65291	65302	-	-	1.81	0.50	-	0.141	5	0.30
Spiral-Point Gun — P, B	65384	-	-	-	1.81	0.50	-	0.141	5	0.30
Regular Spiral — P, B	65498	-	-	-	1.81	0.50	-	0.141	5	0.30
Fast Spiral — P, B	65507	-	-	-	1.81	0.50	-	0.141	5	0.30
M3										
Hand — T, P, B	65292	65303	64852	-	1.94	0.63	-	0.141	5	0.30
Spiral-Point Gun — P, B	65385	-	-	-	1.94	0.63	-	0.141	5	0.30
Fast Spiral — P, B	65508	-	-	-	1.94	0.63	-	0.141	5	0.30
M3.5										
Hand — T, P, B	65293	65304	65850	-	2.00	0.69	-	0.141	7	0.30
Spiral-Point Gun — P, B	65386	64849	-	-	2.00	0.69	-	0.141	7	0.30
Regular Spiral — P, B	-	65515	-	-	2.00	0.38	0.69	0.141	7	0.30
Fast Spiral — P, B	-	65526	-	-	2.00	0.38	0.69	0.141	7	0.30
Oversized										
Hand — T, P, B	-	65783	-	-	2.00	0.69	-	0.141	13	0.30
Spiral-Point Gun — P, B	-	65416	-	-	2.00	0.69	-	0.141	13	0.30
M4										
Hand — T, P, B	65294	65305	65317	-	2.13	0.75	-	0.168	7	0.30
Spiral-Point Gun — P, B	65387	65393	-	-	2.13	0.75	-	0.168	7	0.30
Regular Spiral — P, B	-	65516	-	-	2.13	0.38	0.75	0.168	7	0.30
Fast Spiral — P, B	-	65527	-	-	2.13	0.38	0.75	0.168	7	0.30
Oversized										
Hand — T, P, B	-	65784	65433	-	2.13	0.75	-	0.168	13	0.30
Spiral-Point Gun — P, B	65411	-	-	-	2.13	0.75	-	0.168	13	0.30
M4.5										
Hand — T, P, B	-	65306	65318	-	2.38	0.88	-	0.194	7	0.30
Spiral-Point Gun — P, B	65388	65394	-	-	2.38	0.88	-	0.194	7	0.30
Regular Spiral — P, B	-	65517	-	-	2.38	0.50	0.88	0.194	7	0.30
Fast Spiral — P, B	-	65528	-	-	2.38	0.50	0.88	0.194	7	0.30
Oversized										
Hand — T, P, B	-	-	65434	-	2.38	0.88	-	0.194	13	0.30

(continued)

(continued)

Specials from Blanks • General Applications • HSS

style	uncoated 2-flute	uncoated 3-flute	uncoated 4-flute	uncoated 6-flute	L	L3	L2	D	max D limit	pitch min
M5										
Hand — T, P, B	64259	64271	64280	-	2.38	0.88	-	0.194	7	0.30
Spiral-Point Gun — P, B	64359	65395	64827	-	2.38	0.88	-	0.194	7	0.30
Regular Spiral — P, B	-	65518	-	-	2.38	0.50	0.88	0.194	7	0.30
Fast Spiral — P, B	-	64478	-	-	2.38	0.50	0.88	0.194	7	0.30
Oversized										
Hand — T, P, B	-	65804	65806	-	2.38	0.88	-	0.194	13	0.30
Spiral-Point Gun — P, B	65809	65811	-	-	2.38	0.88	-	0.194	13	0.30
M6										
Hand — T, P, B	65298	65308	65321	-	2.50	1.00	-	0.255	7	0.30
Spiral-Point Gun — P, B	65391	65397	-	-	2.50	1.00	-	0.255	7	0.30
Regular Spiral — P, B	-	65520	-	-	2.50	0.63	1.00	0.255	7	0.30
Fast Spiral — P, B	-	65531	-	-	2.50	0.63	1.00	0.255	7	0.30
Oversized										
Hand — T, P, B	-	65436	65787	-	2.50	1.00	-	0.255	13	0.30
Spiral-Point Gun — P, B	-	65414	65420	-	2.50	1.00	-	0.255	13	0.30
M6.3										
Hand — T, P, B	-	65715	65717	-	2.50	1.00	-	0.255	7	0.30
Spiral-Point Gun — P, B	65768	65770	-	-	2.50	1.00	-	0.255	7	0.30
M7										
Hand — T, P, B	65299	65309	65322	-	2.72	1.13	-	0.318	7	0.30
Spiral-Point Gun — P, B	65392	65398	-	-	2.72	1.13	-	0.318	7	0.30
Regular Spiral — P, B	-	65521	-	-	2.72	0.69	1.12	0.318	7	0.30
Fast Spiral — P, B	-	65532	-	-	2.72	0.69	1.12	0.318	7	0.30
Oversized										
Hand — T, P, B	-	-	65437	-	2.72	1.13	-	0.318	13	0.30
Spiral-Point Gun — P, B	-	65421	-	-	2.72	1.13	-	0.318	13	0.30
M8										
Hand — T, P, B	65711	65716	65718	-	2.72	1.13	-	0.318	7	0.30
Spiral-Point Gun — P, B	65769	65771	64845	-	2.72	1.13	-	0.318	7	0.30
Regular Spiral — P, B	-	65775	-	-	2.72	0.69	1.13	0.318	7	0.30
Fast Spiral — P, B	-	65777	-	-	2.72	0.69	1.13	0.318	7	0.30
Oversized										
Hand — T, P, B	-	65789	65800	-	2.72	1.13	-	0.318	13	0.30
Spiral-Point Gun — P, B	65801	65802	-	-	2.72	1.13	-	0.318	13	0.30
M9										
Hand — T, P, B	65300	65310	65323	-	2.94	1.25	-	0.381	7	0.30
Spiral-Point Gun — P, B	-	65399	-	-	2.94	1.25	-	0.381	7	0.30
Regular Spiral — P, B	-	65522	-	-	2.94	0.75	1.25	0.381	7	0.30
Fast Spiral — P, B	-	65533	-	-	2.94	0.75	1.25	0.381	7	0.30
Oversized										
Hand — T, P, B	-	-	65438	-	2.94	1.25	-	0.381	13	0.30

(continued)

Pricing Based on Order Quantity

min	max
5	24
25	49
50	72

(continued)

Specials from Blanks • General Applications • HSS

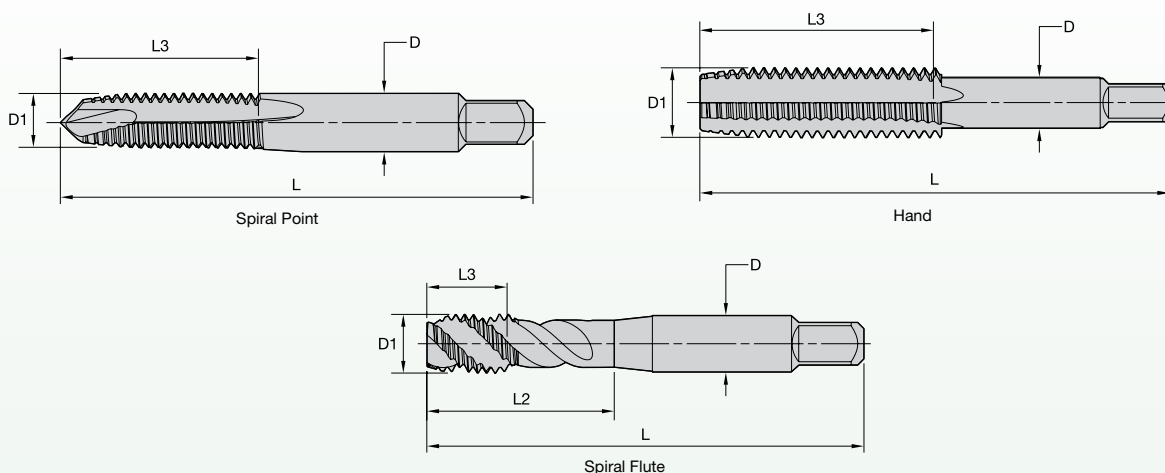

style	uncoated 2-flute	uncoated 3-flute	uncoated 4-flute	uncoated 6-flute	L	L3	L2	D	max D limit	pitch min
M10										
Hand — T, P, B	65712	64275	64285	-	2.94	1.25	-	0.381	7	0.30
Spiral-Point Gun — P, B	64847	64379	-	-	2.94	1.25	-	0.381	7	0.30
Regular Spiral — P, B	-	64473	-	-	2.94	0.75	1.25	0.381	7	0.30
Fast Spiral — P, B	-	64483	-	-	2.94	0.75	1.25	0.381	7	0.30
Oversized										
Hand — T, P, B	-	-	65808	-	2.94	1.25	-	0.381	13	0.30
Spiral-Point Gun — P, B	-	65813	-	-	2.94	1.25	-	0.381	13	0.30
M11										
Hand — T, P, B	-	65312	65325	-	3.16	1.44	-	0.323	15	0.30
Spiral-Point Gun — P, B	-	65401	-	-	3.16	1.44	-	0.323	15	0.30
Fast Spiral — P, B	-	65535	-	-	3.16	0.94	-	0.323	15	0.30
M12										
Hand — T, P, B	-	65313	65326	65719	3.38	1.66	-	0.367	15	0.30
Spiral-Point Gun — P, B	-	65402	-	-	3.38	1.66	-	0.367	15	0.30
Regular Spiral — P, B	-	65525	-	-	3.38	0.94	-	0.367	15	0.30
Fast Spiral — P, B	-	65536	-	-	3.38	0.94	-	0.367	15	0.30
M14										
Hand — T, P, B	-	65314	65327	65720	3.59	1.66	-	0.429	15	0.40
Spiral-Point Gun — P, B	-	65403	-	-	3.59	1.66	-	0.429	15	0.40
Regular Spiral — P, B	-	-	65537	-	3.59	1.00	-	0.429	15	0.40
Fast Spiral — P, B	-	-	65543	-	3.59	1.00	-	0.429	15	0.40
M15										
Hand — T, P, B	-	-	64831	-	3.81	1.81	-	0.480	15	0.40
Spiral-Point Gun — P, B	-	-	-	-	3.81	1.81	-	0.480	15	0.40
M16										
Hand — T, P, B	-	65315	65328	65721	3.81	1.81	-	0.480	15	0.40
Spiral-Point Gun — P, B	-	65404	64828	-	3.81	1.81	-	0.480	15	0.40
Regular Spiral — P, B	-	-	65538	-	3.81	1.09	-	0.480	15	0.40
Fast Spiral — P, B	-	-	65544	-	3.81	1.09	-	0.480	15	0.40
M18										
Hand — T, P, B	-	65316	65329	65722	4.03	1.81	-	0.542	15	0.40
Spiral-Point Gun — P, B	-	65405	64833	-	4.03	1.81	-	0.542	15	0.40
Regular Spiral — P, B	-	-	65539	-	4.03	1.09	-	0.542	15	0.40
Fast Spiral — P, B	-	-	65545	-	4.03	1.09	-	0.542	15	0.40

(continued)

(continued)

Specials from Blanks • General Applications • HSS

style	uncoated 2-flute	uncoated 3-flute	uncoated 4-flute	uncoated 6-flute	L	L3	L2	D	max D limit	pitch min
M20										
Hand — T, P, B	-	-	65330	65723	4.47	2.00	-	0.652	15	0.40
Spiral-Point Gun — P, B	-	65406	-	-	4.47	2.00	-	0.652	15	0.40
Regular Spiral — P, B	-	-	65778	-	4.47	1.22	-	0.652	15	0.40
Fast Spiral — P, B	-	-	65779	-	4.47	1.22	-	0.652	15	0.40
M22										
Hand — T, P, B	-	-	65331	65724	4.69	2.22	-	0.697	15	0.40
Spiral-Point Gun — P, B	-	65407	-	-	4.69	2.22	-	0.697	15	0.40
Regular Spiral — P, B	-	-	65540	-	4.69	1.34	-	0.697	15	0.40
Fast Spiral — P, B	-	-	65546	-	4.69	1.34	-	0.697	15	0.40
M24										
Hand — T, P, B	-	-	65332	65725	4.91	2.22	-	0.760	15	0.40
Spiral-Point Gun — P, B	-	65408	-	-	4.91	2.22	-	0.760	15	0.40
Regular Spiral — P, B	-	-	65541	-	4.91	1.34	-	0.760	15	0.40
Fast Spiral — P, B	-	-	65547	-	4.91	1.34	-	0.760	15	0.40
M25										
Hand — T, P, B	-	-	65333	65726	5.10	2.50	-	0.800	15	0.40
Spiral-Point Gun — P, B	-	65409	-	-	5.13	2.50	-	0.800	15	0.40

Pricing Based on Order Quantity

min	max
5	24
25	49
50	72

Specials from Blanks • STI • HSS

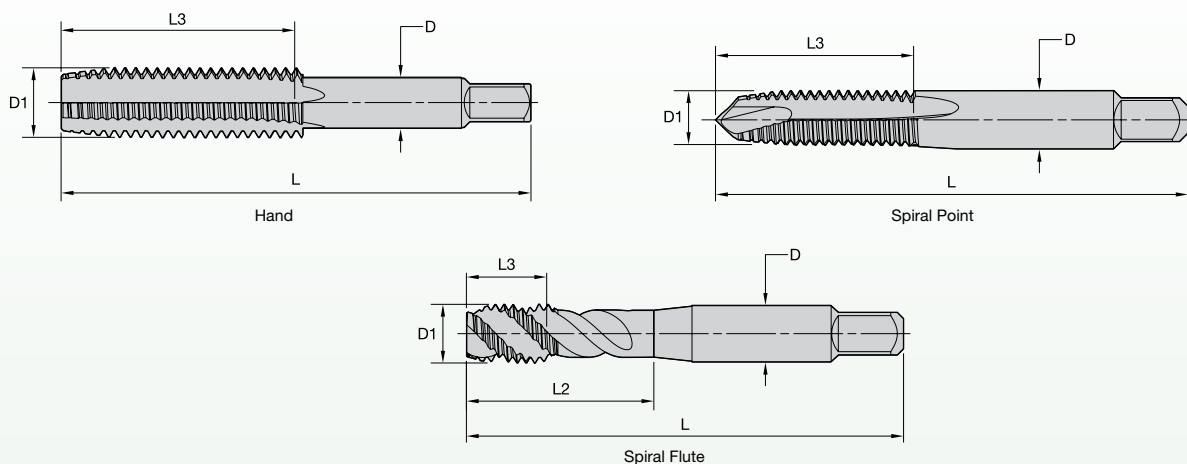

style	uncoated 2-flute	uncoated 3-flute	uncoated 4-flute	L	L3	L2	D	max H limit
2 - 56 NC								
Hand – T, P, B	67604	65286	-	1.75	0.56	-	0.141	5
Spiral-Point Gun – P, B	66291	67660	-	1.75	0.56	-	0.141	5
Regular Spiral – P, B	67701	-	-	1.75	-	-	0.141	5
Fast Spiral – P, B	68281	-	-	1.75	-	-	0.141	5
3 - 48 NC								
Hand – T, P, B	67605	65287	67606	2.00	0.63	-	0.141	5
Spiral-Point Gun – P, B	66292	67661	-	2.00	0.63	-	0.141	5
Regular Spiral – P, B	67702	67703	-	2.00	-	-	0.141	5
Fast Spiral – P, B	68282	68283	-	2.00	-	-	0.141	5
3 - 56 NF								
Hand – T, P, B	-	68376	-	-	-	-	0.141	5
Spiral-Point Gun – P, B	68333	-	-	-	-	-	0.141	5
4 - 40 NC								
Hand – T, P, B	67607	64616	67608	2.00	0.69	-	0.141	7
Spiral-Point Gun – P, B	66293	67662	-	2.00	0.69	-	0.141	7
Regular Spiral – P, B	67704	67705	-	2.00	-	-	0.141	7
Fast Spiral – P, B	68284	68285	-	2.00	-	-	0.141	7
4 - 48 NF								
Hand – T, P, B	-	68315	-	2.00	0.69	-	0.141	7
Spiral-Point Gun – P, B	72015	-	-	2.00	0.69	-	0.141	7
5 - 40 NC								
Hand – T, P, B	67609	64617	67610	2.13	0.75	-	0.168	7
Spiral-Point Gun – P, B	66294	67663	-	2.13	0.75	-	0.168	7
Regular Spiral – P, B	67706	67707	-	2.13	-	-	0.168	7
Fast Spiral – P, B	68286	68287	-	2.13	-	-	0.168	7
6 - 32 NC								
Hand – T, P, B	67611	64618	67612	2.38	0.88	-	0.194	7
Spiral-Point Gun – P, B	66295	67664	-	2.38	0.88	-	0.194	7
Regular Spiral – P, B	67708	68472	-	2.38	0.69	0.88	0.194	7
Fast Spiral – P, B	68288	68317	-	2.38	0.69	0.88	0.194	7
6 - 40 NF								
Hand – T, P, B	-	68316	-	2.38	0.88	-	0.194	7
Spiral-Point Gun – P, B	68323	-	-	2.38	0.88	-	0.194	7
Fast Spiral – P, B	-	68411	-	2.38	0.69	0.88	0.194	7
8 - 32 NC								
Hand – T, P, B	64830	65147	67613	2.38	0.94	-	0.220	7
Spiral-Point Gun – P, B	66296	67665	67666	2.38	0.94	-	0.220	7
Regular Spiral – P, B	-	67709	-	2.38	0.75	0.94	0.220	7
Fast Spiral – P, B	-	68289	-	2.38	0.75	0.94	0.220	7

(continued)

(continued)

Specials from Blanks • STI • HSS

style	uncoated 2-flute	uncoated 3-flute	uncoated 4-flute	L	L3	L2	D	max H limit
8 - 36 NF								
Hand — T, P, B	67614	66281	67615	2.38	0.94	-	0.220	7
Spiral-Point Gun — P, B	66297	67667	67668	2.38	0.94	-	0.220	7
Regular Spiral — P, B	-	67710	-	2.38	0.75	0.94	0.220	7
Fast Spiral — P, B	-	68290	-	2.38	0.75	0.94	0.220	7
10 - 24 NC								
Hand — T, P, B	67616	64619	67617	2.50	1.00	-	0.255	7
Spiral-Point Gun — P, B	64653	67669	67670	2.50	1.00	-	0.255	7
Regular Spiral — P, B	-	67711	-	2.50	0.88	1.00	0.255	7
Fast Spiral — P, B	-	68291	-	2.50	0.88	1.00	0.255	7
10 - 32 NF								
Hand — T, P, B	67619	66282	67620	2.50	1.00	-	0.255	7
Spiral-Point Gun — P, B	66298	67671	67672	2.50	1.00	-	0.255	7
Regular Spiral — P, B	-	67712	-	2.50	0.88	1.00	0.255	7
Fast Spiral — P, B	-	68292	-	2.50	0.88	1.00	0.255	7
1/4 - 20 NC								
Hand — T, P, B	67622	64621	67623	2.72	1.13	-	0.318	7
Spiral-Point Gun — P, B	64655	67673	67674	2.72	1.13	-	0.318	7
Regular Spiral — P, B	-	67713	-	2.72	0.63	1.00	0.318	7
Fast Spiral — P, B	-	68293	-	2.72	0.63	1.00	0.318	7
1/4 - 28 NF								
Hand — T, P, B	67625	66283	67626	2.72	1.13	-	0.318	7
Spiral-Point Gun — P, B	66299	67675	67676	2.72	1.13	-	0.318	7
Regular Spiral — P, B	-	67714	-	2.72	0.63	1.00	0.318	7
Fast Spiral — P, B	-	68294	-	2.72	0.63	1.00	0.318	7
5/16 - 18 NC								
Hand — T, P, B	67628	67629	64630	2.94	1.25	-	0.381	7
Spiral-Point Gun — P, B	67677	64565	67678	2.94	1.25	-	0.381	7
Regular Spiral — P, B	-	67715	-	2.94	1.12	1.25	0.381	7
Fast Spiral — P, B	-	68295	-	2.94	1.12	1.25	0.381	7
5/16 - 24 NF								
Hand — T, P, B	67631	67632	66284	2.94	1.25	-	0.381	7
Spiral-Point Gun — P, B	67679	66300	67680	2.94	1.25	-	0.381	7
Regular Spiral — P, B	-	67716	-	2.94	1.12	1.25	0.381	7
Fast Spiral — P, B	-	68296	-	2.94	1.12	1.25	0.381	7
3/8 - 16 NC								
Hand — T, P, B	-	67634	64631	3.38	1.66	-	0.367	7
Spiral-Point Gun — P, B	-	64657	67681	3.38	1.66	-	0.367	7
Regular Spiral — P, B	-	67717	-	3.38	1.25	1.66	0.367	7
Fast Spiral — P, B	-	68297	-	3.38	1.25	1.66	0.367	7
3/8 - 24 NF								
Hand — T, P, B	-	67636	66285	3.38	1.66	-	0.367	7
Spiral-Point Gun — P, B	-	66301	67682	3.38	1.66	-	0.367	7
Regular Spiral — P, B	-	67718	-	3.38	1.25	1.66	0.367	7
Fast Spiral — P, B	-	68298	-	3.38	1.25	1.66	0.367	7

(continued)

Pricing Based on Order Quantity

min	max
5	24
25	49
50	72

(continued)

Specials from Blanks • STI • HSS

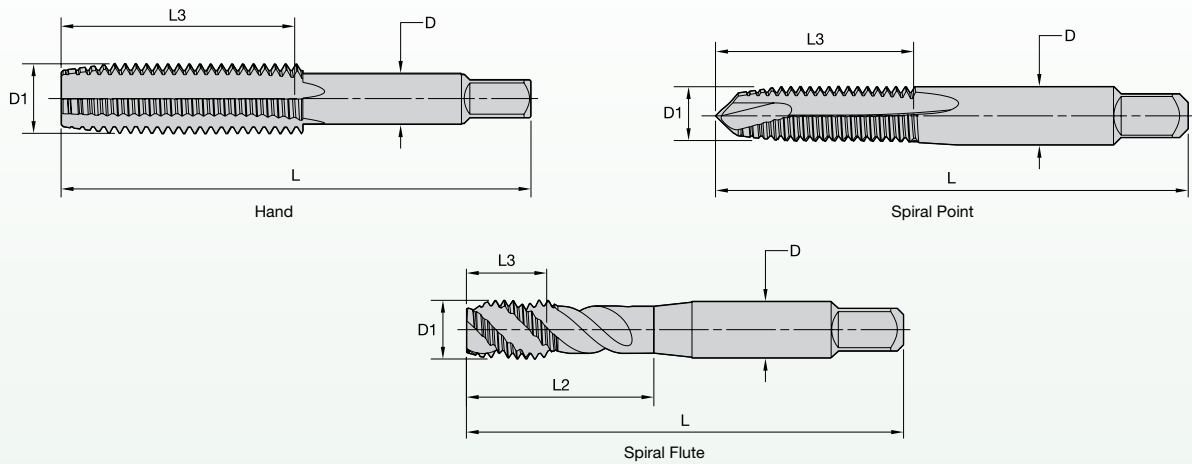

style	uncoated 2-flute	uncoated 3-flute	uncoated 4-flute	L	L3	L2	D	max H limit
7/16 - 14 NC								
Hand – T, P, B	-	67638	64632	3.59	1.66	-	0.429	15
Spiral-Point Gun – P, B	-	64658	67683	3.59	1.66	-	0.429	15
Regular Spiral – P, B	-	67719	-	3.59	-	-	0.429	15
Fast Spiral – P, B	-	68299	-	3.59	-	-	0.429	15
7/16 - 20 NF								
Hand – T, P, B	-	67640	66286	3.59	1.66	-	0.429	15
Spiral-Point Gun – P, B	-	66302	67684	3.59	1.66	-	0.429	15
Regular Spiral – P, B	-	67720	-	3.59	-	-	0.429	15
Fast Spiral – P, B	-	68300	-	3.59	-	-	0.429	15
1/2 - 13 NC								
Hand – T, P, B	-	67642	64633	3.81	1.81	-	0.480	15
Spiral-Point Gun – P, B	-	64659	67685	3.81	1.81	-	0.480	15
Regular Spiral – P, B	-	67721	-	3.81	-	-	0.480	15
Fast Spiral – P, B	-	68301	-	3.81	-	-	0.480	15
1/2 - 20 NF								
Hand – T, P, B	-	67644	66287	3.81	1.81	-	0.480	15
Spiral-Point Gun – P, B	-	66309	67686	3.81	1.81	-	0.480	15
Regular Spiral – P, B	-	67722	-	3.81	-	-	0.480	15
Fast Spiral – P, B	-	68302	-	3.81	-	-	0.480	15
9/16 - 12 NC								
Hand – T, P, B	-	67646	-	3.81	1.81	-	0.480	15
Spiral-Point Gun – P, B	-	67687	67688	3.81	1.81	-	0.480	15
Regular Spiral – P, B	-	67723	-	3.81	-	-	0.480	15
Fast Spiral – P, B	-	68303	-	3.81	-	-	0.480	15
9/16 - 18 NF								
Hand – T, P, B	-	67648	66288	3.81	1.81	-	0.480	15
Spiral-Point Gun – P, B	-	67689	67690	3.81	1.81	-	0.480	15
Regular Spiral – P, B	-	67724	-	3.81	-	-	0.480	15
Fast Spiral – P, B	-	68304	-	3.81	-	-	0.480	15
5/8 - 11 NC								
Hand – T, P, B	-	67650	64635	4.25	2.00	-	0.590	15
Spiral-Point Gun – P, B	-	67691	67692	4.25	2.00	-	0.590	15
Regular Spiral – P, B	-	67725	-	4.25	-	-	0.590	15
Fast Spiral – P, B	-	68305	-	4.25	-	-	0.590	15

(continued)

(continued)

Specials from Blanks • STI • HSS

style	uncoated 2-flute	uncoated 3-flute	uncoated 4-flute	L	L3	L2	D	max H limit
5/8 - 18 NF								
Hand — T, P, B	-	67652	66289	4.25	2.00	-	0.590	15
Spiral-Point Gun — P, B	-	67693	67694	4.25	2.00	-	0.590	15
Regular Spiral — P, B	-	67726	-	4.25	-	-	0.590	15
Fast Spiral — P, B	-	68306	-	4.25	-	-	0.590	15
3/4 - 10 NC								
Hand — T, P, B	-	67654	64636	4.69	2.22	-	0.697	15
Spiral-Point Gun — P, B	-	67695	67696	4.69	2.22	-	0.697	15
Regular Spiral — P, B	-	67727	-	4.69	-	-	0.697	15
Fast Spiral — P, B	-	68307	-	4.69	-	-	0.697	15
3/4 - 16 NF								
Hand — T, P, B	-	67656	66290	4.69	2.22	-	0.697	15
Spiral-Point Gun — P, B	-	67697	67698	4.69	2.22	-	0.697	15
Regular Spiral — P, B	-	67728	-	4.69	-	-	0.697	15

Pricing Based on Order Quantity

min	max
5	24
25	49
50	72

Specials from Blanks • Internal Coolant • HSS

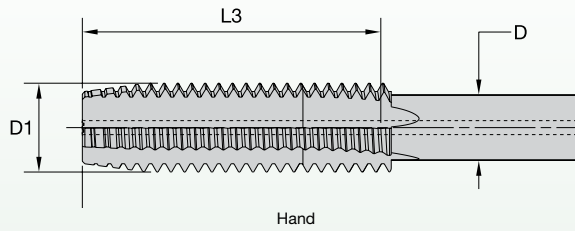

style	uncoated	flutes	L	L3	D	max H limit	max TPI
3/8" Hand — Plug or Bottom	65753	3	2.94	0.75	0.381	13	80
7/16" Hand — Plug or Bottom	65754	4	3.16	0.88	0.323	13	80
1/2" Hand — Plug or Bottom	65755	4	3.38	0.94	0.367	13	80
9/16" Hand — Plug or Bottom	65756	4	3.59	1.00	0.429	13	64
5/8" Hand — Plug or Bottom	65757	4	3.81	1.09	0.480	13	64
3/4" Hand — Plug or Bottom	65758	4	4.25	1.22	0.590	13	64
1" Hand — Plug or Bottom	65760	4	5.13	1.50	0.800	13	64

Pricing Based on Order Quantity

min	max
5	24
25	49
50	72

Specials from Blanks • Form Taps • HSS

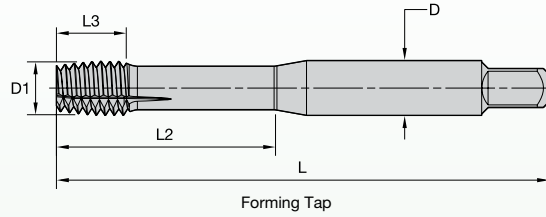

style	uncoated	oil grooves	L	L3	L2	D	max H limit	max TPI
#0								
Plug or Bottom	64508	-	1.63	0.31	-	0.141	7	100
#1								
Plug or Bottom	64509	-	1.69	0.38	-	0.141	7	100
#2								
Plug or Bottom	64510	-	1.75	0.44	-	0.141	11	100
#3								
Plug or Bottom	64511	-	1.81	0.50	-	0.141	11	100
#4								
Plug or Bottom	64512	-	1.88	0.56	-	0.141	11	100
#5								
Plug or Bottom	64513	4	1.94	0.63	-	0.141	11	100
#6								
Plug or Bottom	64514	4	2.00	0.38	0.69	0.141	11	100
#8								
Plug or Bottom	64515	4	2.13	0.38	0.75	0.168	13	100
#10								
Plug or Bottom	64516	4	2.38	0.50	0.88	0.194	13	100
#12								
Plug or Bottom	64518	4	2.38	0.50	0.94	0.220	13	100
1/4"								
Plug or Bottom	64519	4	2.50	0.63	1.00	0.255	13	80
5/16"								
Plug or Bottom	64520	4	2.72	0.69	1.13	0.318	13	80
3/8"								
Plug or Bottom	64521	4	2.94	0.75	1.25	0.381	13	80
7/16"								
Plug or Bottom	64523	4	3.16	0.88	-	0.323	15	80
1/2"								
Plug or Bottom	64524	4	3.38	0.94	-	0.367	15	80

(continued)

(continued)

Specials from Blanks • Form Taps • HSS

style	uncoated	oil grooves	L	L3	L2	D	max H limit	max TPI
M1.6								
Plug or Bottom	65549	-	1.63	0.31	-	0.141	7	0.3
M1.8								
Plug or Bottom	65550	-	1.69	0.38	-	0.141	7	0.3
M2								
Plug or Bottom	65551	-	1.75	0.44	-	0.141	11	0.3
M2.5								
Plug or Bottom	65552	-	1.81	0.50	-	0.141	11	0.3
M3								
Plug or Bottom	65553	4	1.94	0.63	-	0.141	11	0.3
M3.5								
Plug or Bottom	65554	4	2.00	0.38	0.69	0.141	11	0.3
M4								
Plug or Bottom	65555	4	2.13	0.38	0.75	0.168	13	0.3
M4.5								
Plug or Bottom	65556	4	2.38	0.50	0.88	0.194	13	0.3
M5								
Plug or Bottom	64517	4	2.38	0.50	0.88	0.194	13	0.3
M6								
Plug or Bottom	65559	4	2.50	0.63	1.00	0.255	13	0.3
M8								
Plug or Bottom	65560	4	2.72	0.69	1.13	0.318	13	0.3
M9								
Plug or Bottom	65561	4	2.94	0.75	1.25	0.381	13	0.3
M10								
Plug or Bottom	64522	4	2.94	0.75	1.25	0.381	13	0.3
M11								
Plug or Bottom	65563	4	3.16	0.88	-	0.323	15	0.3
M12								
Plug or Bottom	65564	4	3.38	0.94	-	0.367	15	0.3

Pricing Based on Order Quantity

min	max
5	24
25	49
50	72